

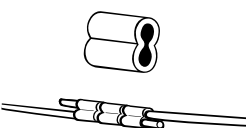
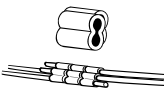
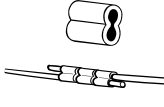
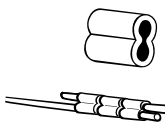
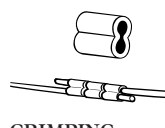
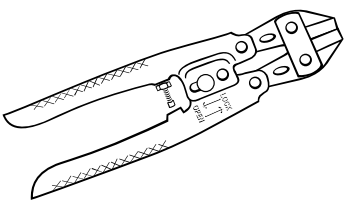

# High-Tensile Fencing

## Accessories

<p><b>SF-20424</b></p>  <p><b>CRIMPING SLEEVE 1-2</b> Used with 14 ga. and 15 ga. wire.</p> <p>PKG 25/BAG</p>	<p><b>SF-20415</b></p>  <p><b>CRIMPING SLEEVE 2-3</b> Used with 12 ga. wire.</p> <p>100/BAG</p>	<p><b>SF-20425</b></p>  <p><b>CRIMPING SLEEVE 2-3</b> Used with 12 ga. wire.</p> <p>25/BAG</p>	<p><b>SF-20426</b></p>  <p><b>CRIMPING SLEEVE 3-4</b> Used with 10 and 11 ga. wire and 14 and 15 ga. barbed wire.</p> <p>10/BAG</p>	<p><b>SF-20427</b></p>  <p><b>CRIMPING SLEEVE 4-5</b> Used with 9 ga. wire and 13 and 13 ga. barbed wire. When tying wire off to itself, use two sleeves butted together.</p> <p>10/BAG</p>	<p><b>Gripple</b></p> <p>2881 - (Small) Fits 17-13 GA smooth wire. 20/BAG</p> <p>2882 - (Medium) Fits smooth 14-10 GA High Tensile, including 12 1/2 GA H.T. 20/BAG</p> <p>2883 - (Large) Fits smooth 10-7.5 GA. 10/BAG</p> <p>2886 - (Maxi) Fits smooth 7 - 8 GA (.177/.120") &amp; 12 1/2 GA barbed. 10/BAG</p>
--	--	---	--	---	---

<p><b>SF-20310</b></p>  <p><b>HIGH TENSILE WIRE CUTTER</b> Specially hardened jaws to cut 12 gauge high-tensile fence wire. Comfortably shaped handles lock closed to carry, spring open to use.</p> <p>PKG 2/BOX</p>	<p><b>SF-20402</b> 5" GALVANIZED BRACE PIN</p>  <p><b>SF-20403</b> 10" GALVANIZED BRACE PIN</p>  <p>constructed from 3/8" carbon steel rods and galvanized. Use 400-402T with 6"x8" post in each single or double brace assembly. Use 400-403T with 5"x8" post and 4"x8" post in double brace assembly.</p> <p>PKG 5/BAG 10/CTN</p>	<p><b>2212</b></p>  <p><b>Under Ground Insulation.</b> Double insulation over galvanized steel wire. Perfect for underground use and to connect fencer to line wire. 14 ga. x 164' on plastic spool.</p> <p>4/BOX</p>
--	--	--

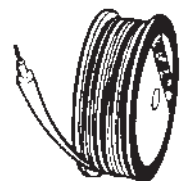
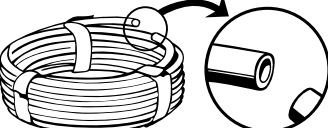
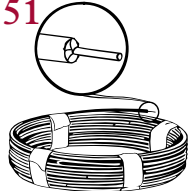
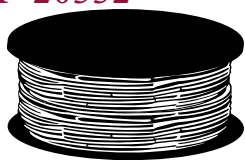
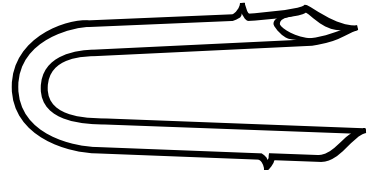
<p><b>SF-20546</b></p>  <p><b>50' INSULTUBE.</b> Used for insulating hot feed wires to be strung overhead or underground to bring electricity to the fence. Can also be cut to insulate live wires from neutral wires. Also used to enclose wires buried underground for crossing underneath gateways.</p> <p>1/BOX</p>	<p><b>SF-20551</b></p>  <p><b>50' UNDERGROUND CABLE.</b> Is used in the same manner as #500-546 to the left, except you don't have to thread the wire thru the tubing. The underground cable is made of non-conductive polyethylene, which is extruded around 12ga. 170,000 PSI Class 3 galvanized wire.</p> <p>1/BOX</p>	<p><b>SF-20552</b></p>  <p><b>200' UNDERGROUND CABLE.</b> Is used in the same manner as #500-546 to the left, except you don't have to thread the wire thru the tubing. The underground cable is made of non-conductive polyethylene, which is extruded around 12ga. 170,000 PSI Class 3 galvanized wire.</p> <p>1/BOX</p>	<p><b>400-407T</b></p>  <p><b>1-3/4" BARBED FENCING STAPLES.</b> Top quality, made from Class 3 galvanized wire, which lasts 3 times longer than Class 1 staples. Solves the problem of loosening line wires by increasing the staple's grip in the post.</p> <p>5 #/BOX</p>
---	--	--	---

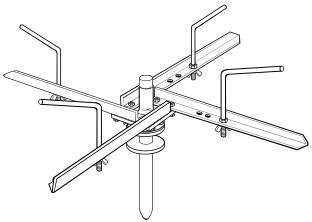
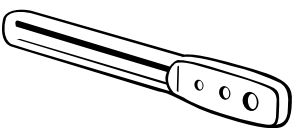
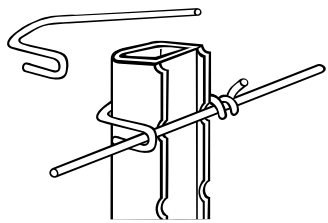
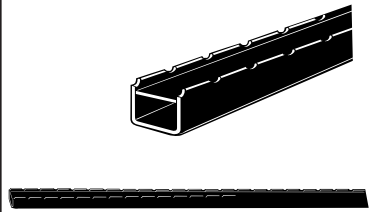
<p><b>SF-20303</b></p>  <p><b>SPINNING JENNY WITH BRAKE</b> Allows easy payout for coiled wire. Includes built-in brake to prevent wire from uncoiling. Assembly required.</p> <p>PKG 1</p>	<p><b>SF-20309</b></p>  <p><b>3 HOLE TWISTING TOOL</b> Primarily used to wrap #400-430 M.G. clips to wire, but extra holes give it a use for 12 ga., and 9 ga. wire twisting.</p> <p>10/BOX</p>	<p><b>SF-20430</b></p>  <p><b>M.G. POLY-SPACER CLIP</b> Multi-groove poly-spacer clip with galvanized finish is used in conjunction with the multi-groove poly-spacer #200-260. Attaches spacer tightly to high-tensile wire.</p> <p>25/BAG 10 BAGS/CTN</p>	<p><b>200-260</b></p>  <p><b>MULTI GROOVE POLY SPACER.</b> Made of high quality polyethylene. UV stabilized, notched every inch.</p> <p>12 PER BUNDLE</p>
--	--	---	--

Call toll free: 1-800-858-0485