

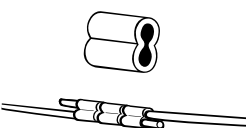
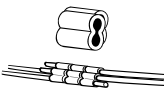
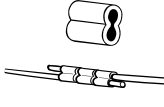
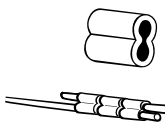
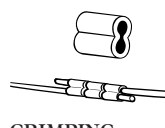
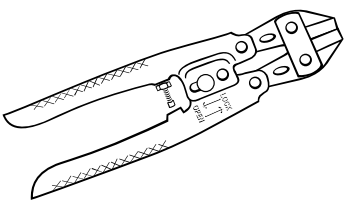

# High-Tensile Fencing

## Accessories

<p><b>SF-20424</b></p>  <p><b>CRIMPING SLEEVE 1-2</b> Used with 14 ga. and 15 ga. wire.</p> <p>PKG 25/BAG</p>	<p><b>SF-20415</b></p>  <p><b>CRIMPING SLEEVE 2-3</b> Used with 12 ga. wire.</p> <p>100/BAG</p>	<p><b>SF-20425</b></p>  <p><b>CRIMPING SLEEVE 2-3</b> Used with 12 ga. wire.</p> <p>25/BAG</p>	<p><b>SF-20426</b></p>  <p><b>CRIMPING SLEEVE 3-4</b> Used with 10 and 11 ga. wire and 14 and 15 ga. barbed wire.</p> <p>10/BAG</p>	<p><b>SF-20427</b></p>  <p><b>CRIMPING SLEEVE 4-5</b> Used with 9 ga. wire and 13 and 13 ga. barbed wire. When tying wire off to itself, use two sleeves butted together.</p> <p>10/BAG</p>	<p><b>Gripple</b></p> <p>2881 - (Small) Fits 17-13 GA smooth wire. 20/BAG</p> <p>2882 - (Medium) Fits smooth 14-10 GA High Tensile, including 12 1/2 GA H.T. 20/BAG</p> <p>2883 - (Large) Fits smooth 10-7.5 GA. 10/BAG</p> <p>2886 - (Maxi) Fits smooth 7 - 8 GA (.177/.120") &amp; 12 1/2 GA barbed. 10/BAG</p>
----------------------------------------------------------------------------------------------------------------------------------------------------------------------------------------------------	--------------------------------------------------------------------------------------------------------------------------------------------------------------------------------------	-------------------------------------------------------------------------------------------------------------------------------------------------------------------------------------	--------------------------------------------------------------------------------------------------------------------------------------------------------------------------------------------------------------------------	-----------------------------------------------------------------------------------------------------------------------------------------------------------------------------------------------------------------------------------------------------------------------------------	-------------------------------------------------------------------------------------------------------------------------------------------------------------------------------------------------------------------------------------------------------------------------------------------------------------------

<p><b>SF-20310</b></p>  <p><b>HIGH TENSILE WIRE CUTTER</b> Specially hardened jaws to cut 12 gauge high-tensile fence wire. Comfortably shaped handles lock closed to carry, spring open to use.</p> <p>PKG 2/BOX</p>	<p><b>SF-20402</b> 5" GALVANIZED BRACE PIN</p>  <p><b>SF-20403</b> 10" GALVANIZED BRACE PIN</p>  <p>constructed from 3/8" carbon steel rods and galvanized. Use 400-402T with 6"x8" post in each single or double brace assembly. Use 400-403T with 5"x8" post and 4"x8" post in double brace assembly.</p> <p>PKG 5/BAG 10/CTN</p>	<p><b>2212</b></p>  <p>Under Ground Insulation. Double insulation over galvanized steel wire. Perfect for underground use and to connect fencer to line wire. 14 ga. x 164' on plastic spool.</p> <p>4/BOX</p>
------------------------------------------------------------------------------------------------------------------------------------------------------------------------------------------------------------------------------------------------------------------------------------------------------------	----------------------------------------------------------------------------------------------------------------------------------------------------------------------------------------------------------------------------------------------------------------------------------------------------------------------------------------------------------------------------------------------------------------------------------------------------------------------------------------------------------------	---------------------------------------------------------------------------------------------------------------------------------------------------------------------------------------------------------------------------------------------------------------------------------------------------

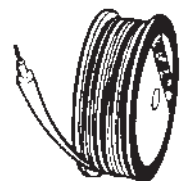
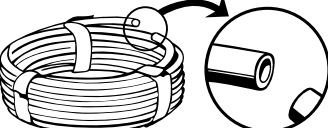
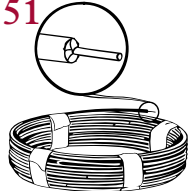
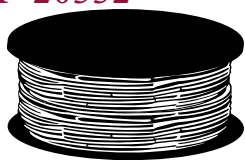
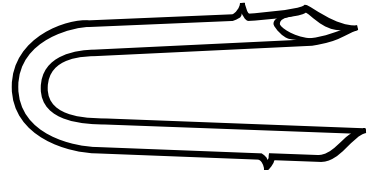
<p><b>SF-20546</b></p>  <p><b>50' INSULTUBE.</b> Used for insulating hot feed wires to be strung overhead or underground to bring electricity to the fence. Can also be cut to insulate live wires from neutral wires. Also used to enclose wires buried underground for crossing underneath gateways.</p> <p>1/BOX</p>	<p><b>SF-20551</b></p>  <p><b>50' UNDERGROUND CABLE.</b> Is used in the same manner as #500-546 to the left, except you don't have to thread the wire thru the tubing. The underground cable is made of non-conductive polyethylene, which is extruded around 12ga. 170,000 PSI Class 3 galvanized wire.</p> <p>1/BOX</p>	<p><b>SF-20552</b></p>  <p><b>200' UNDERGROUND CABLE.</b> Is used in the same manner as #500-546 to the left, except you don't have to thread the wire thru the tubing. The underground cable is made of non-conductive polyethylene, which is extruded around 12ga. 170,000 PSI Class 3 galvanized wire.</p> <p>1/BOX</p>	<p><b>400-407T</b></p>  <p><b>1-3/4" BARBED FENCING STAPLES.</b> Top quality, made from Class 3 galvanized wire, which lasts 3 times longer than Class 1 staples. Solves the problem of loosening line wires by increasing the staple's grip in the post.</p> <p>5 #/BOX</p>
------------------------------------------------------------------------------------------------------------------------------------------------------------------------------------------------------------------------------------------------------------------------------------------------------------------------------------------------------------------------------------------------------------	--------------------------------------------------------------------------------------------------------------------------------------------------------------------------------------------------------------------------------------------------------------------------------------------------------------------------------------------------------------------------------------------------------------	----------------------------------------------------------------------------------------------------------------------------------------------------------------------------------------------------------------------------------------------------------------------------------------------------------------------------------------------------------------------------------------------------------------	-------------------------------------------------------------------------------------------------------------------------------------------------------------------------------------------------------------------------------------------------------------------------------------------------------------------------------------------------------------------

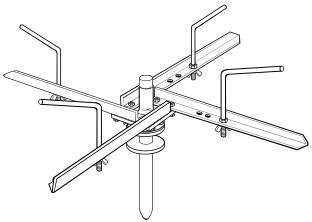
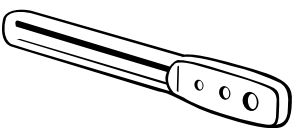
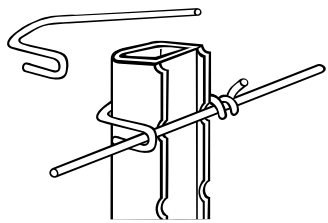
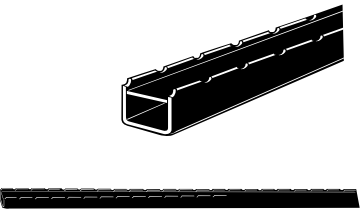



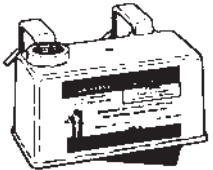
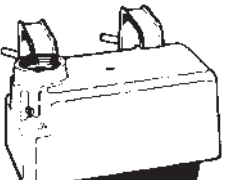
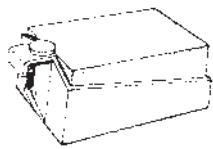

<p><b>SF-20303</b></p>  <p><b>SPINNING JENNY WITH BRAKE</b> Allows easy payout for coiled wire. Includes built-in brake to prevent wire from uncoiling. Assembly required.</p> <p>PKG 1</p>	<p><b>SF-20309</b></p>  <p><b>3 HOLE TWISTING TOOL</b> Primarily used to wrap #400-430 M.G. clips to wire, but extra holes give it a use for 12 ga., and 9 ga. wire twisting.</p> <p>10/BOX</p>	<p><b>SF-20430</b></p>  <p><b>M.G. POLY-SPACER CLIP</b> Multi-groove poly-spacer clip with galvanized finish is used in conjunction with the multi-groove poly-spacer #200-260. Attaches spacer tightly to high-tensile wire.</p> <p>25/BAG 10 BAGS/CTN</p>	<p><b>200-260</b></p>  <p><b>MULTI GROOVE POLY SPACER.</b> Made of high quality polyethylene. UV stabilized, notched every inch.</p> <p>12 PER BUNDLE</p>
------------------------------------------------------------------------------------------------------------------------------------------------------------------------------------------------------------------------------------------------------------------------------------	----------------------------------------------------------------------------------------------------------------------------------------------------------------------------------------------------------------------------------------------------------------------------------------	-------------------------------------------------------------------------------------------------------------------------------------------------------------------------------------------------------------------------------------------------------------------------------------------------------------------------------------------------	------------------------------------------------------------------------------------------------------------------------------------------------------------------------------------------------------------------------------------------------

Call toll free: 1-800-858-0485

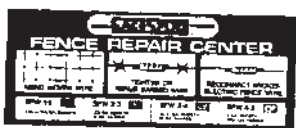
## Float Valves

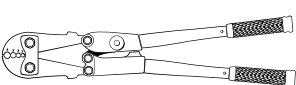
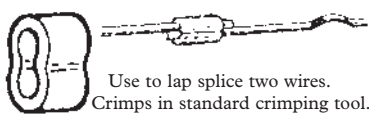
<p><b>798</b></p>  <p>Capacity up to 300GPH. Tough hi-impact weather resistant plastic housing. Operates from 3/4" garden hose. Styrofoam float protected in styrene case cannot be punctured like a hollow float. Replaceable orifice. Plated hanging brackets and screws</p>	<p><b>1780</b></p>  <p>Capacity up to 300 GPH. Die-cast aluminum housing. Operates from 3/4" garden hose. Brass hose thread liners stops corrosion. Styrofoam float cannot be punctured like a hollow float. Replaceable orifice. Plated hanging brackets and screws.</p>	<p><b>1041</b></p>  <p>Replacement float assemblies for 766, 767, 1527, 1780, 1800, 1530, 798, and 1801.</p>
QTY 6	QTY 6	QTY 1

## Fence Splicing Equipment

<p><b>Free Splicing Center Display</b></p> 	<p><b>CT-1 SACO Splice/Cut Tool</b></p>  <p>Repairs any wire fencing. Including barbed, woven, and electric high tensile. Splice or cut wit this versatile tool 18" dual purpose tool with adjustable case. One Year Warranty</p>	<p><b>SF-20320 Splice tool</b></p>  <p>Multi-groove hand tool to press sleeves SFW 1-2 thru SFW 5-6 and line taps FWT 3-4 and FWT 4-5.</p>	<p><b>Aluminum Splicing Sleeves</b></p>  <p>Use to lap splice two wires. Crimps in standard crimping tool.</p> <p>SF-20424A: For 17 ga. electric wire - 25/BAG SF-20425A: For 12 ga. hi-tensile wire - 25/BAG SF-20415A: For 15 ga. barbed wire - 100/BAG SF-20426A: For 9 ga. smooth and some 12 ga barbed wire - 10/BAG SF-20427A: For 12 ga. barbed wire - 10/BAG</p>
<p><b>LBW1 Wire Splices</b></p>  <p>12 1/2 - 14 gauge wire or 9 gauge smooth wire. One splice per joint.</p>	<p><b>400-456 Wire Link</b></p>  <p>In-line mechanical splice. Used for splicing two smooth 12 1/2 gauge wires by inserting both wires as far as possible into the ends of the link.</p>	<p><b>SF-20560 Wire Taps</b></p>  <p>FWT3-4. 12 1/2 to 14 1/2 GA smooth &amp; 15 1/2 GA barbed fence wire to 12 1/2 - 16 GA smooth hook-up wire. Not a splice. Use to connect hook-up or grounding wire to fence. Crimps in standard crimping tool.</p>	
PKG 100/BOX	PKG 1	PKG 1	PKG 1

## Aluminum Wire

Item #	Description	Pkg.	Wt. Pkg.	Breaking	Tensile Strength
AW250	150' 17 gauge	16	16#	90#	38000PSI
AW1320	1/4 mile - 17 gauge	8	31#	90#	38000PSI
AW2640	1/2 mile - 17 gauge	4	29#	90#	38000PSI
FW07	1/4 mile - 14 gauge	8	64#	215#	38000PSI
FW08	1/2 mile - 14 gauge	4	64#	215#	38000PSI
FW04	1/4 mile - 15 gauge	8	53#	150#	38000PSI
FW21	1/4 mile - 12 1/2 gauge	4	56#	360#	50000PSI

## Steel Wire

Item #	Description	Pkg.	Wt. Pkg.	Breaking	Tensile Strength
WC100	100 ft coil, 17 gauge	25	14	125-145	90,000-105,000
WC250	250 ft coil, 17 gauge	12	15	125-145	90,000-105,000

Call toll free: 1-800-858-0485